

Point Cloud Observation Device that can be Inserted into a Cavity Observation Hole Under the Road Surface

路面下空洞観測孔に挿入可能な点群観測装置

This several year, the problems by the under-road-cavity keep increasing. We wanted to know the figure and capacity about the cavity in order to filling the it. The MHz radar is good way to find it, but it is not good way to figure out the capacity. Because this observation device can 3d-imagenize the inside of the cavity, now we can get the figure and capacity by using this, just rotate this by your hands..

この数年、都市成熟型の路面下空洞を原因とする問題が増え続けている。そこで、空洞を充填するために形状や容量を知っておきたいという要望があった。MHz帯のレーダは空洞の発見には有用なもの、空洞の詳細な形状を把握するにはあまり良い方法ではなかった。この観測機器は空洞内部を3Dイメージ化できる為、この機器を手で回すだけで、空洞の容量と形状を把握することができる。

What is Point Cloud and LIDAR

The **point cloud** is one of the technology that **detect the figure**. For example, used for the face recognition in case of unlocking your device. This system is used sensor, called "LIDAR". By the way, this sensor is used the automatic driving system or the drone. The LIDAR has two method by broadly divided, 2D or 1D. The 2D one use grid pattern exposure or another way, but it's expensive. The 1D is only single point distance.

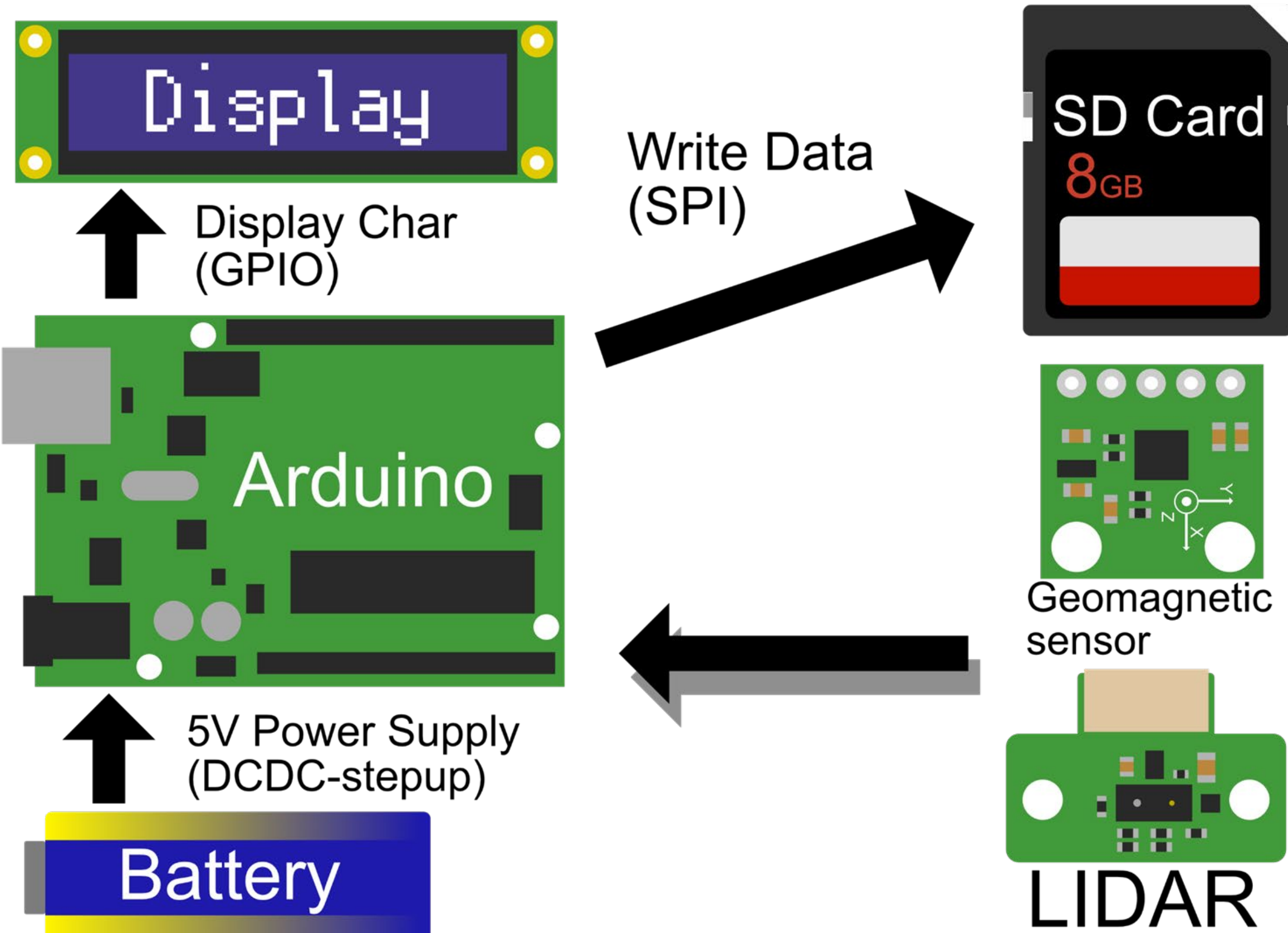
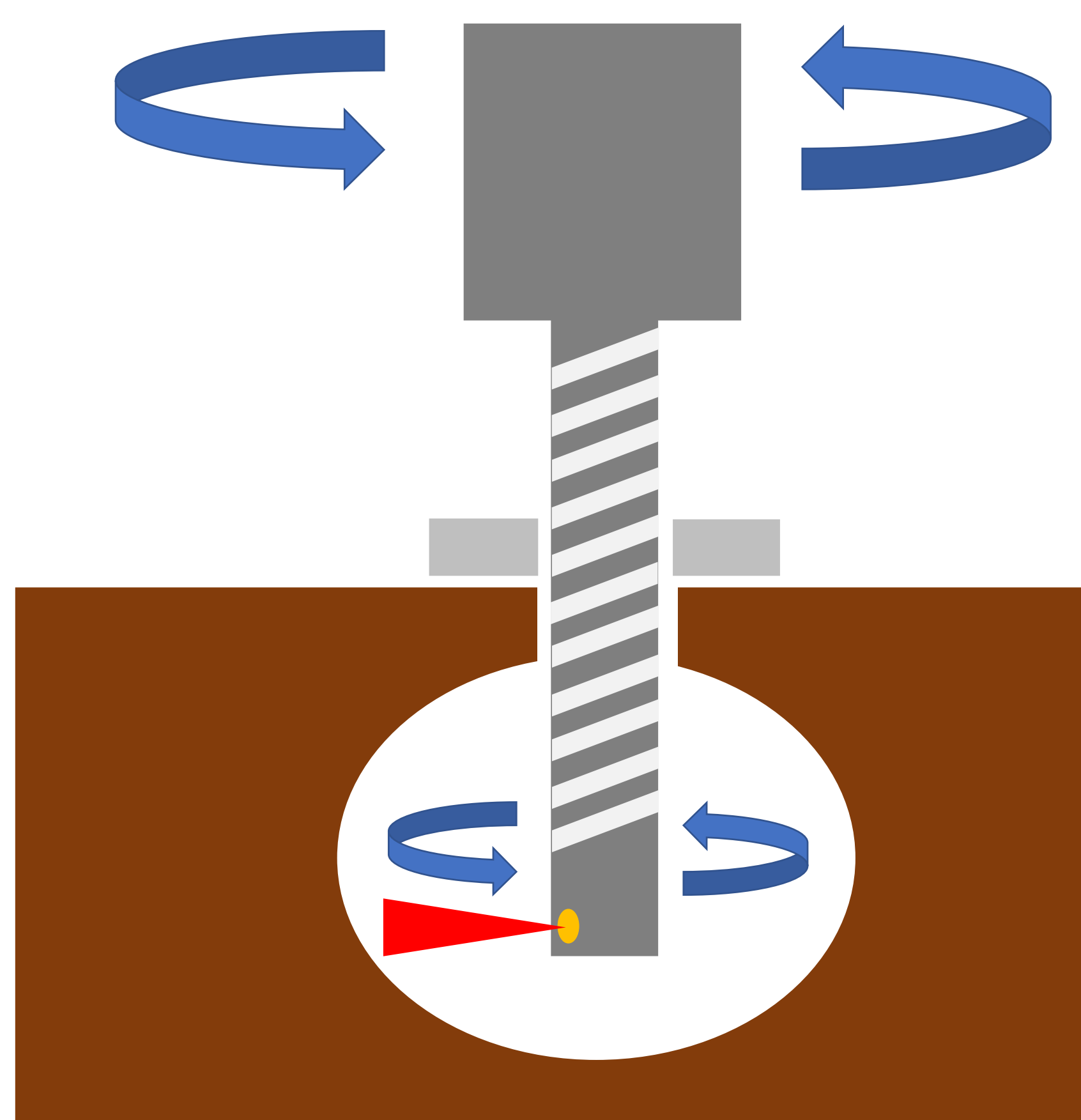

Test Result

Here is two example. The top one is the cardboard box that has some various objects (cardboard boxed, can, ball). The second is the handmade cavity under road surface. As you can see, the top result has **good details, works well**. The second result doesn't look quite good. It seems that this cavity had many unexpected object inside, because this cavity was handmade. LIDAR is just laser, so it is not good at an obstacle that is between sensor to the target object.



Various objects in cardboard box



Simulated cavity under road surface

